

CB-E**S* 双向齿轮泵

CB-E**S* BIDIRECTIONAL GEAR PUMPS

简介 General Description

CB-E**S* 双向齿轮泵是一种小排量液压泵，它由一对齿轮轴、轴套，一个泵体、前盖、后盖组成。其中后盖含有两个单向阀，因此可同时实现正反向工作，适用于小型双向液压系统中。

CB-E**S* Bidirectional Gear Pump has a low displacement. It consists of a gear pair supported by bearing blocks, a housing, a flange and a rear cover. Equipped with two check valves in the rear cover, the pump can work in both cw and ccw direction. It is suitable for small bidirectional hydraulic systems.

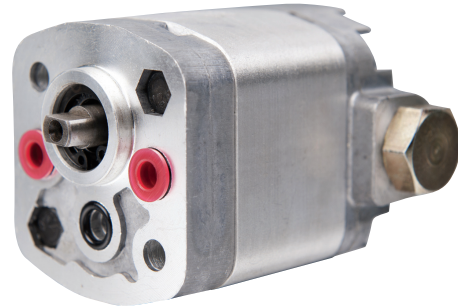

型谱 Order Code

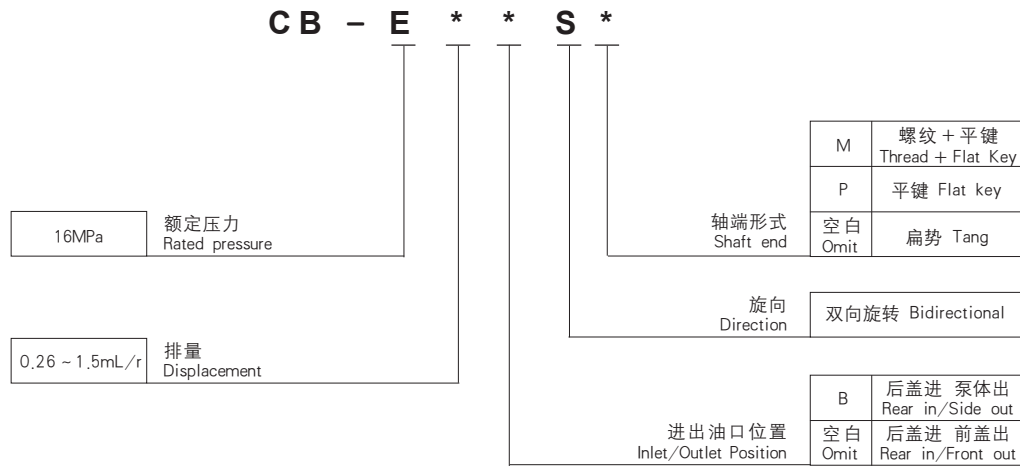

外形尺寸图 Outline Dimension

CB-E*S

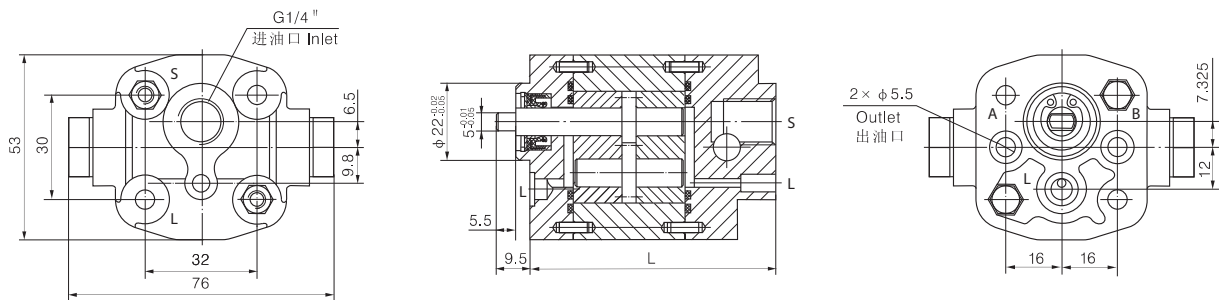

CB-E*BS

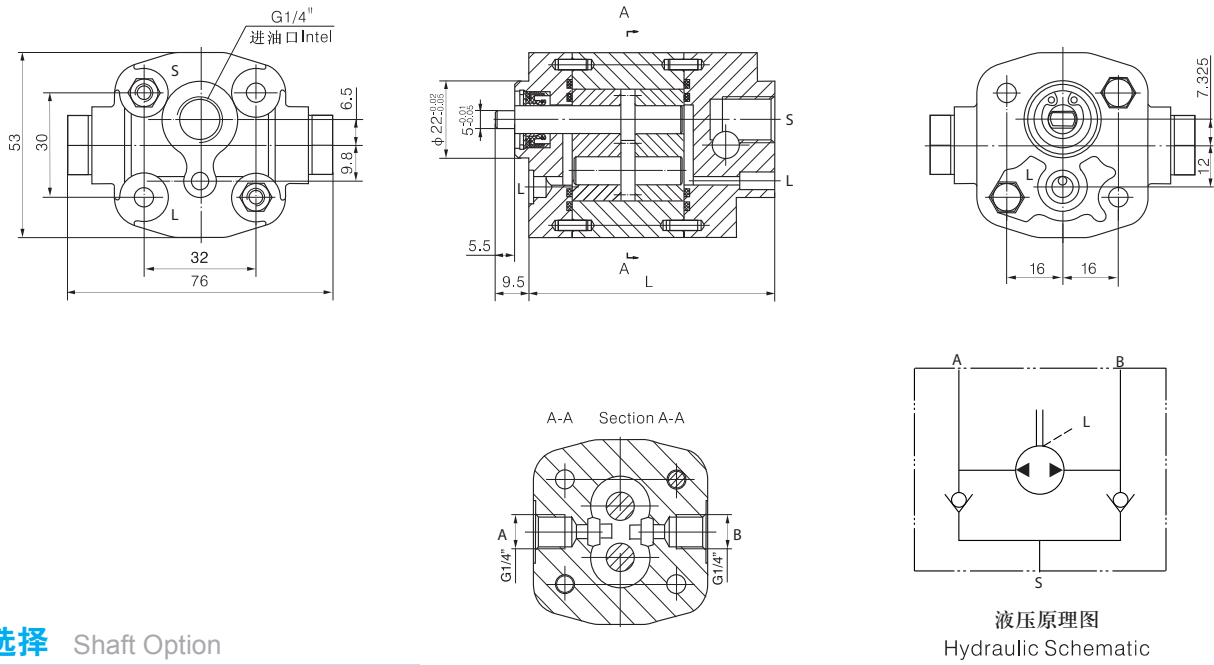

轴端选择 Shaft Option

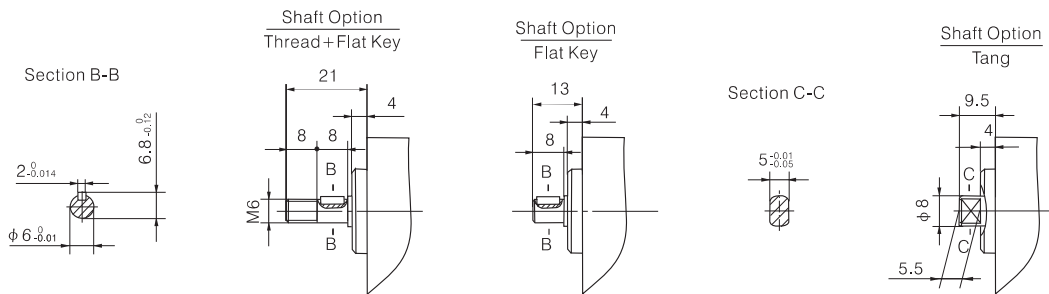

技术参数 Technical Data

Model 型号	Displacement 排量 (mL/r)	压力 pressure (MPa)			Speed (RPM) 转速	尺寸 Displacement L(mm)	Efficiency 容积效率
		P1	P2	P3			
CB-E0.26*S*	0.27	16	18	20	3000	68.7	80%
CB-E0.32*S*	0.33					69.2	
CB-E0.38*S*	0.39					82%	69.6
CB-E0.50*S*	0.49						70.5
CB-E0.60*S*	0.61						71.5
CB-E0.63*S*	0.64						71.7
CB-E0.75*S*	0.76						72.7
CB-E0.88*S*	0.88						73.7
CB-E1.00*S*	1.00					85%	74.7
CB-E1.25*S*	1.25						76.7
CB-E1.50*S*	1.54	79					