

CB-G 齿轮泵

CB-G GEAR PUMPS



简介 General Description

CB-G 齿轮油泵采用粉末冶金前、后盖和泵体、高强度齿轮、SAE 花键轴，结构简单合理，性能稳定，且该齿轮泵具有体积小、噪音低、效率高和寿命长等优点。适用于各种液压动力单元和小型的高压液压系统。

CB-G Gear Pump consists of a gear pair, two shafts, a housing, a front cover and a rear cover. It has a fixed axial clearance. The CB-G pump features high mechanical and volumetric efficiency, low noise level as well as low weight/power ratio. It has been widely used in DC power units for almost all applications.



型谱 Order Code

CB - G * * * *			
20MPa	额定压力 Rated Pressure		
2 ~ 6mL/r	排量 Displacement		
由厂方确定 Manufacturer determines	内部结构 Internal Structure		
A、B、C、D			
		轴端形式 Shaft end	空白 Omit
			9 齿花键 9T Spline
			16 齿花键 16T Spline
		旋向 Direction	空白 Omit
			顺时针 CW
			F 逆时针 CCW

外形尺寸图 Outline Dimension

CB-G**F

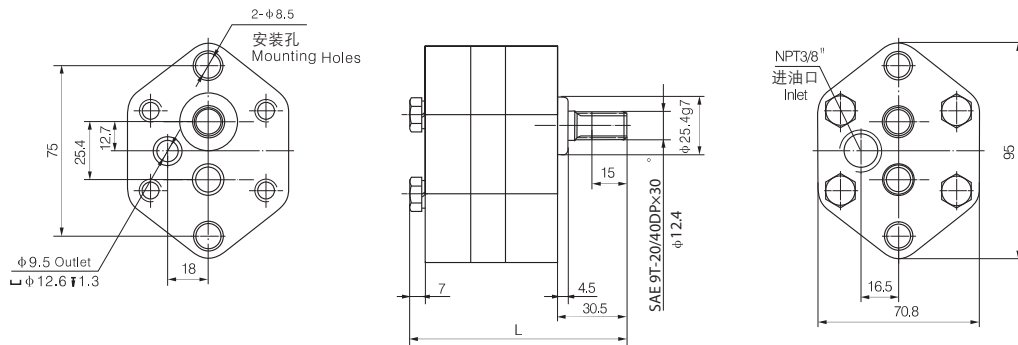

CB-G**F16

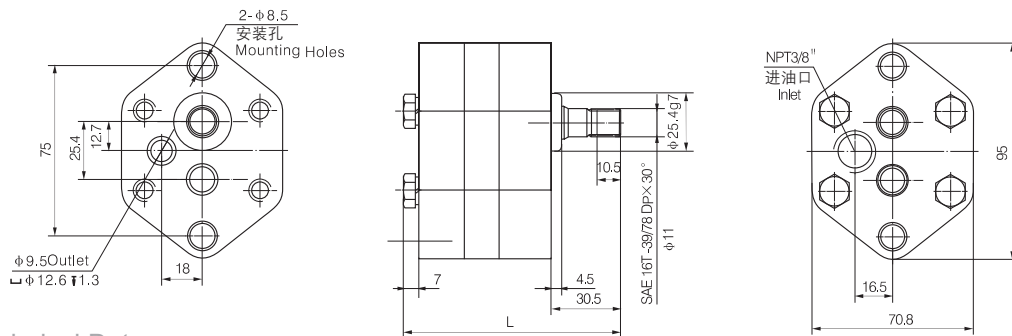

技术参数 Technical Data

Model 型号	Displacement 排量 mL/r (in ³ /r)	压力 pressure (MPa)			转速 Speed (RPM)		L(mm)	Efficiency 容积效率
		P1	P2	P3	额定 Rated (RPM)	最高 Max (RPM)		
CB-G2***	2.1 (0.128)	20	25	28	2000	3000	89	80%
CB-G3***	3.18 (0.186)						91.5	
CB-G3.6***	3.6 (0.220)						93.2	
CB-G4***	4.2 (0.256)						95.5	
CB-G5***	4.9 (0.299)						98	
CB-G6***	6.08 (0.371)						101.5	