

CB2A 双联齿轮泵

CB2A DOUBLE GEAR PUMPS

简介 General Description

CB2A 双联齿轮泵是由两个高压齿轮泵组成，包括前盖、泵体、中体和后盖，另外还有两对高强度齿轮和高精度浮动轴套。该泵具有较高的机械效率和容积效率，噪声低，稳定性高，适用于需要双泵供油的各种较大流量液压系统，如挖掘机，装载机等。

Consisting of 2 high pressure gear pumps, the CB2A Double pumps feature high mechanical and volumetric efficiency, low noise level as well as high reliability. They are widely used in the hydraulic systems where 2 independent power sources are required, such as excavators, loading machines, etc.



型谱 Order Code

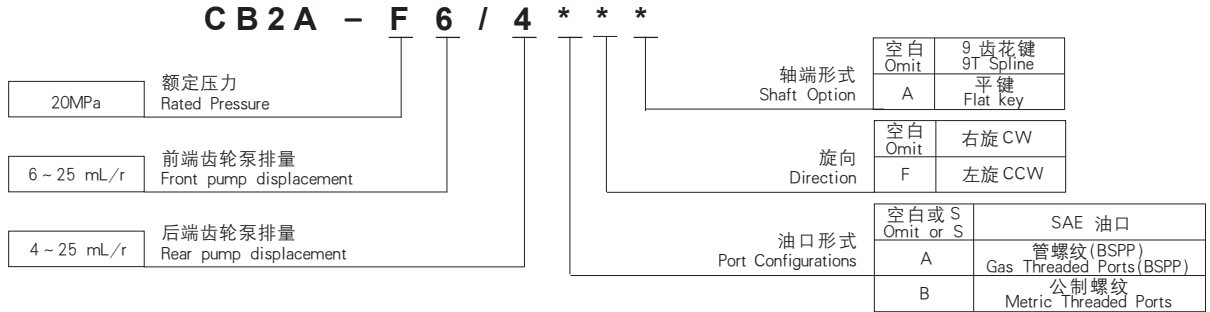

外形尺寸图 Outline Dimension

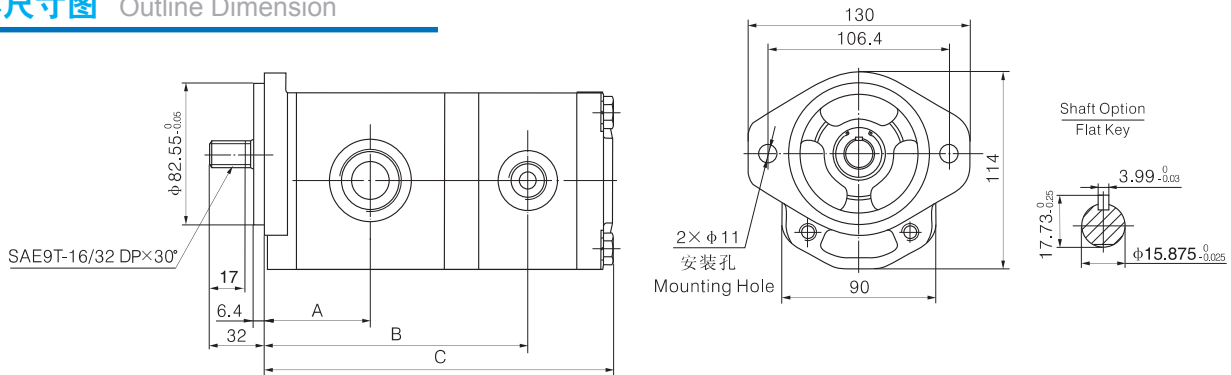

技术参数 Technical Data

Model 型号	Displacement 排量 mL/r (in ³ /r)		Working Pressure 工作压力 MPa(Psi)		Max Pressure 最大压力 MPa(Psi)		转速 Speed RPM	进油口 Inlet		出油口 Outlet		Dimension 尺寸 (mm)		
	Front 前端	Rear 后端	Front 前端	Rear 后端	Front 前端	Rear 后端		Front 前端	Rear 后端	Front 前端	Rear 后端	A	B	C
CB2A-F6/4*	6.37(0.389)	4.47(0.273)										47.1	122	169.7
CB2A-F7/4*	7.01(0.428)	4.47(0.273)										47.7	123.2	170.9
CB2A-F11/7*	11.49(0.701)	7.01(0.428)										51.3	132.5	182.3
CB2A-F11/9*	11.49(0.701)	9.57(0.584)	21 (3000)	21 (3000)	24.5 (3500)	24.5 (3500)	600-3500	SAE Port 1-1/16-12UN	SAE Port 1-1/16-12UN	SAE Port 7/8-14UN	SAE Port 7/8-14UN	51.3	134.4	186.1
CB2A-F11/11*	11.49(0.701)	11.49(0.701)										51.3	136.1	189.5
CB2A-F15/7*	15.94(0.973)	7.01(0.428)										54.9	139.7	189.5
CB2A-F15/11*	15.94(0.973)	11.49(0.701)										54.9	143.3	196.7
CB2A-F15/15*	15.94(0.973)	15.94(0.973)										54.9	146.9	203.9
CB2A-F23/7*	23.61(1.441)	7.01(0.428)	17.5 (2500)	17.5 (2500)	21 (3000)	21 (3000)	600-2600	公制口 M27 × 2	公制口 M22 × 2	公制口 M22 × 2	公制口 M22 × 2	60.9	151.7	201.5
CB2A-F23/15*	23.61(1.441)	15.94(0.973)										60.9	158.9	215.9
CB2A-F23/23*	23.61(1.441)	23.61(1.441)										60.9	164.9	227.9
CB2A-F25/7*	25.10(1.532)	7.01(0.428)										62.9	154.7	204.5
CB2A-F25/15*	25.10(1.532)	15.94(0.973)										62.9	161.9	218.9
CB2A-F25/25*	25.10(1.532)	25.10(1.532)	15.4 (2200)		17.5 (2500)			SAE Port 1-5/16-12UN	SAE Port 1-1/16-12UN	SAE Port G3/4"	SAE Port G3/4"	62.9	169.4	226.4