

CBK 1 齿轮泵

CBK1 GEAR PUMPS

简介 General Description

CBK 1 齿轮泵系高压小排量齿轮油泵，由一对高强度齿轮、轴套、泵体、前盖、后盖等主要部件组成，轴向间隙由高精度浮动轴套自动补偿，使得 CBK 1 齿轮泵具有高的机械效率和容积效率，该泵噪音低、重量功率比小，广泛应用各种交流和直流液压力单元和中小型液压系统。

用户订货时应注意，CBK 1 齿轮泵有顺时针、逆时针两种转向及后盖进/前盖出、泵体进/后盖出、后盖进/泵体出、泵体进/泵体出、后盖进/后盖出五种进出油方式。

The CBK1 gear pump consists of a gear pair supported by two aluminum bearing blocks, a housing, front cover and rear cover. The axis clearance can be automatically compensated by the bearing blocks. The CBK1 pump features high mechanism and volume efficiency, low noise level as well as low weight/power ratio.

Notes: The CBK1 gear pump has five options of inlet/outlet positions: rear in/front out, side in/rear out, rear in/side out, side in/side out, rear in/rear out. Both CW and CCW direction pumps are available.

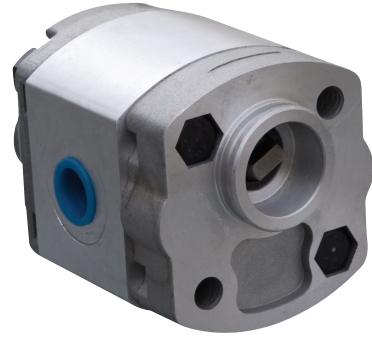

型谱 Order Code

CBK1 - F * * *

20MPa	额定压力 Rated pressure				
0.63 - 8 mL/r	排量 Displacement				
D	后盖进 / 后盖出 Rear in / rear out				
C	泵体进 / 泵体出 Side in / side out				
B	后盖进 / 泵体出 Rear in / side out				
A	泵体进 / 后盖出 Side in / rear out				
空白 Omit	后盖进 / 前盖出 Rear in / front out	进出油位置 Inlet/outlet Position			

空白 Omit	顺时针 CW
F	逆时针 CCW

旋向
Direction

外形尺寸图 Outline Dimension

CBK1-F*F Outline Dimension (Rear in/front out)

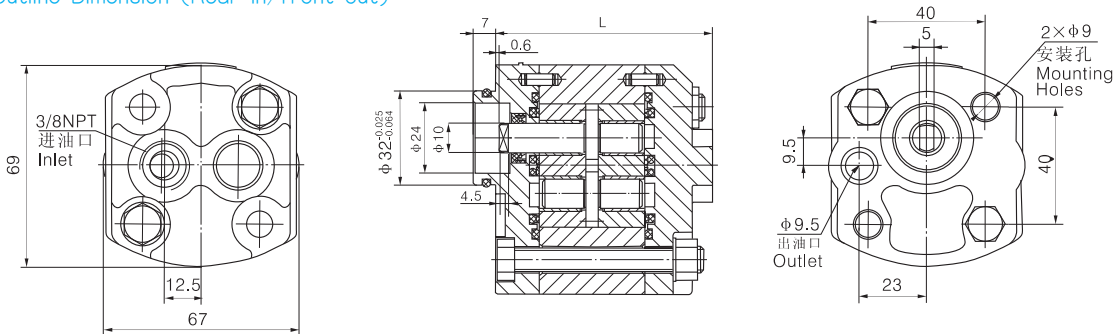

CBK1-F*AF Outline Dimension (Side in/rear out)

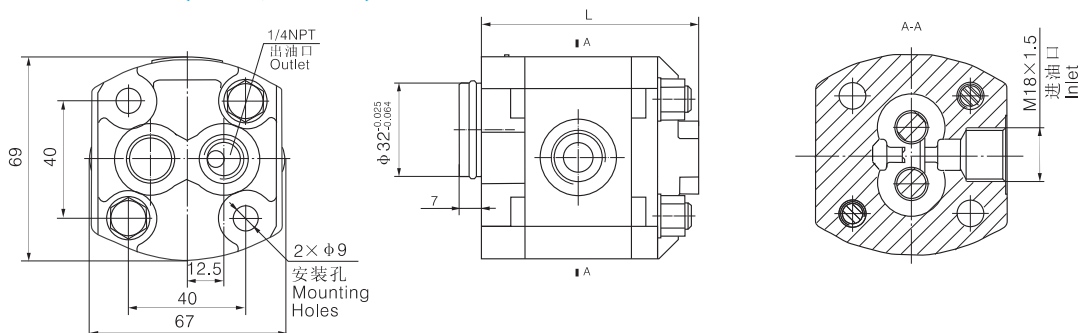

CBK1-F*B Outline Dimension (Rear in/side out)

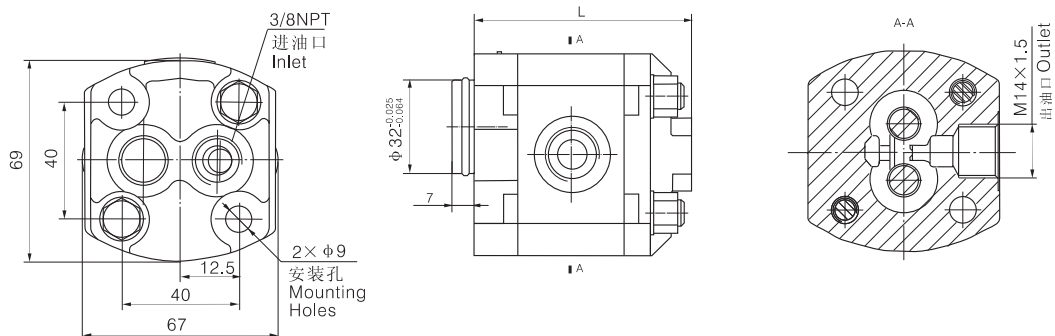

CBK1-F*CF Outline Dimension (Side in/side out)

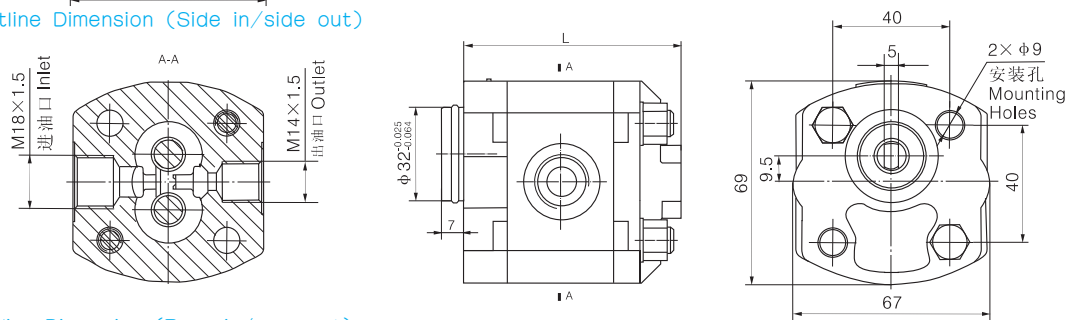

CBK1-F*DF Outline Dimension (Rear in/rear out)

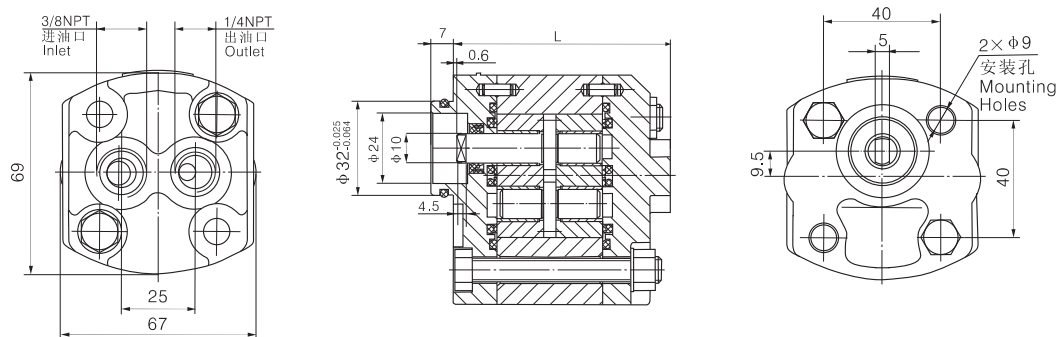

技术参数 Technical Data

Model 型号	Displacement 排量 mL/r(in ³ /r)	压力 pressure (MPa)			转速 Speed (RPM)		L(mm)	Efficiency 容积效率	
		P1	P2	P3	额定 Rated (RPM)	最高 Max (RPM)			
CBK1-F0.63**	0.63 (0.038)	20	25	28	2000	4000	75	85%	
CBK1-F0.8**	0.89 (0.054)						76		
CBK1-F1.2**	1.27 (0.078)						77.5		
CBK1-F1.5**	1.487 (0.091)						78.3		
CBK1-F1.6**	1.66 (0.101)						79		
CBK1-F2.0**	2.05 (0.125)						80.5	88%	
CBK1-F2.1**	2.17 (0.132)						81		
CBK1-F2.5**	2.56 (0.156)						82.5		
CBK1-F2.7**	2.8 (0.171)						83.5		
CBK1-F3.2**	3.32 (0.203)						85.5		
CBK1-F3.7**	3.8 (0.232)	18	23	26	2000	3600	87.5	89%	
CBK1-F4.2**	4.3 (0.263)						89.5		
CBK1-F5**	5.1 (0.311)						92.5	1500	3000
CBK1-F6**	6.03 (0.368)	14	18	23	96				
CBK1-F8**	8.08 (0.493)	10	14	18					