

堆高车动力单元 1

FORK LIFT POWER UNITS 1

简介 General Description

此液压动力单元由高压齿轮油泵、直流电机、多用集成块、液压阀、油箱等零部件有机结合为一体，系典型的动力上升、重力下降液压回路。启动电机，实现上升，打开电磁卸荷阀，实现下降，下降速度由内置平衡阀自动控制。本系列产品是各种堆高车、小型升降平台等物流设备的理想动力源。

Equipped with a high pressure gear pump, a DC motor, a multi-functional manifold, valves and a tank etc. This power unit features power up gravity down function. Start the motor to lift the machine and the lowering movement is activated by the solenoid valve with the lowering speed controlled by the pressure compensated flow control valve. Products of this series can be widely used in the industry of logistic devices such as fork lift, mini lift table etc.



外形尺寸图 Outline Dimension

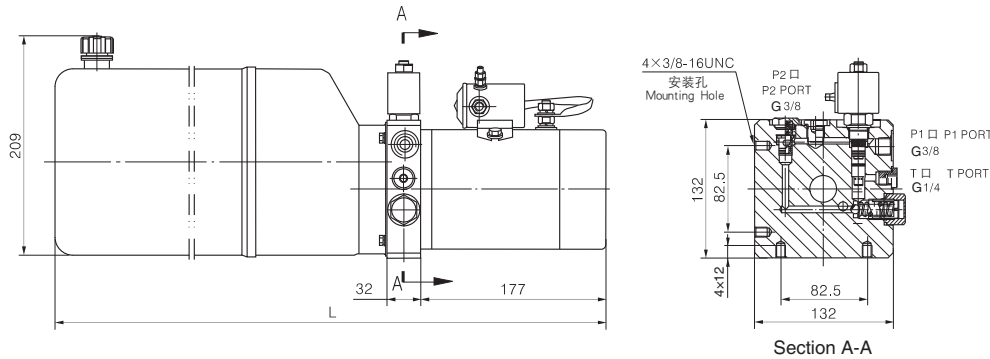

系统工作原理

Hydraulic Circuit Diagram

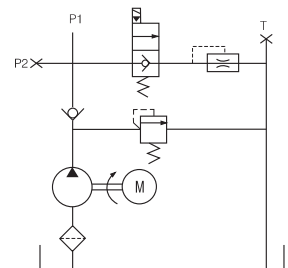

型号规格说明 Model Specifications

Model 型号	Motor Volt 电机电压	Motor power 电机功率	Rated Speed 名义转速	Displacement 油泵排量	System pressure 溢流阀压力	Tank Capacity 油箱容量	L(mm)
YBZ5-F1.2A1W2/WUAAD1	12VDC	1.5KW	2500 RPM	1.2mL/r	20MPa	3.5L	409
YBZ5-F1.6B1W2/WUAAD1				1.6mL/r		5L	459
YBZ5-F2.1B1W2/WUAAD1				2.1mL/r		5L	459
YBZ5-F2.1B2A2/WUABD1	24VDC	2KW		2.1mL/r		6L	509
YBZ5-F2.5C2A2/WUABD1				2.5mL/r		8L	579
YBZ5-F2.7C2A2/WUABD1				2.7mL/r		8L	579

说明: 1.如需不同流量的泵、压力、电机功率等系统参数, 请查看液压动力单元型号说明。

2.如手动应急放油装置, 请在订货时说明。

Remark: 1. Please go to page 38 or consult our sales engineer for the different pump displacement, motor power or tank capacity.

2. The manual override function is available on request.

注意事项 Special Notes

1. 此动力单元工作制为S3工作制, 不可连续运转, 30秒开, 270秒停。
2. 按装前必须保证油缸、油管、接头等液压元件清洁无任何杂质粘附。
3. 液压油粘度应为15~68CST, 应清洁无杂质, 推荐使用N46号液压油。
4. 系统使用第一个100小时后, 应更换液压油, 以后每3000小时更换一次液压油。
5. 本液压动力单元适用于水平安装。

1. The duty of this power unit is S3, i.e., 30 seconds on and 270 seconds off.
2. Clean all the hydraulic parts concerned before mounting the power unit.
3. Viscosity of the hydraulic oil should be 15~68 cst, which should also be clean and free of impurities. N46 hydraulic oil is recommended.
4. Oil changing is required after the initial 100 operation hours, afterwards once every 3000 hours.
5. The power unit should be mounted horizontally.