

登车桥动力单元1

POWER UNITS FOR DOCK LEVELER 1

德力液压 **Deli**®

简介 General Description

此动力单元专为登车桥设计，由高压齿轮泵、交流电机、多用集成块、各式液压阀、油箱等零部件有机结合为一体。主甲板上升到位后，唇板自动上升，主甲板和唇板的下降由电磁阀实现，主甲板和唇板的下降速度由节流阀调节，使下降速度在可靠的范围内。

This power unit is designed exclusively for the dock leveler, consisting of high pressure gear pump, DC motor, multi-functional manifold, valves and tank, etc. Once the ramp is fully lifted, the lip rises automatically. Both lowering movements are activated by the solenoid valves with speeds adjusted by the throttles.

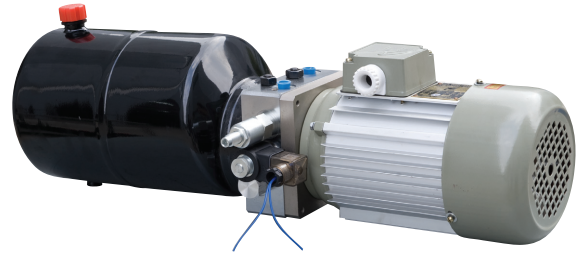

外形尺寸图 Outline Dimension

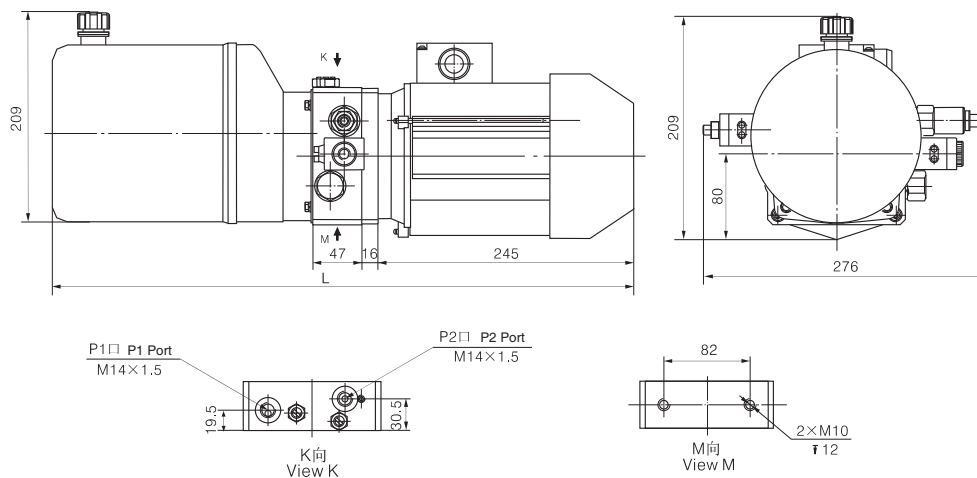

系统工作原理

Hydraulic Circuit Diagram

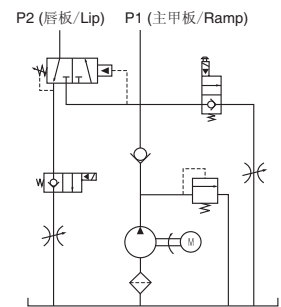

型号规格说明 Model Specifications

Model 型号	Motor Volt 电机电压	Motor power 电机功率	Displacement 油泵排量	System pressure 溢流阀压力	Tank Capacity 油箱容量	L(mm)
YBZ-E2.1B4E10/2	380VAC	0.75KW	2.1mL/r	16MPa	5L	558
YBZ-E2.7B4E10/2			2.7mL/r	14MPa		

说明: 1. 如需不同流量的泵、压力、电机功率等系统参数, 请查看液压动力单元型号说明。

2. 如需手动应急放油装置, 请在订货时说明。

3. 如需订购 CSA 或 UL 认证, 60HZ 的动力单元, 请在订购时说明。

Remark: 1. Please go to page 38 or consult our sales engineer for the different pump displacement, motor power or tank capacity.

2. The manual override function is available on request.

3. 60HZ motors with CSA or UL certification are available upon request.

注意事项 Special Notes

1. 此动力单元不可连续运转 (1 分钟 ON, 9 分钟 OFF), 可重复工作。
2. 按装前必须保证油缸、油管、接头等液压元件清洁无任何杂质粘附。
3. 液压油粘度应为 15 ~ 68CST, 应清洁无杂质, 推荐使用 N46 号液压油。
4. 首次启动运行系统后, 应立即检查油箱中的油量是否充足。
5. 系统使用第一个 100 小时后, 应更换液压油, 以后每 3000 小时更换一次液压油。

1. The power unit is of S3 duty, which can only be worked intermittently, i.e., 1minute on and 9 minutes off.

2. Clean all the hydraulic parts concerned before mounting the power unit.

3. Viscosity of the hydraulic oil should be 15~68 cst, which should also be clean and free of impurities. N46 hydraulic oil is recommended.

4. Check the oil level in the tank after the first start of the power unit.

5. Change the oil after the first 100 hours of running the power unit, then change the oil every 3000 hours.