

登车桥动力单元 6

POWER UNITS FOR DOCK LEVELER 6

简介 General Description

本动力单元适用于带急停功能的浮动式登车桥，主平台上升到位后唇板自动打开，电机停转后平台下降，而唇板落到装货车辆后平台浮动，在下降过程中如使电磁阀带电则实现急停功能，平台和唇板的下降速度由节流阀调节。

This power unit is designed for those dock levellers which need floating ramps with an emergency stop function. The ramp will rise when the pump is running. The lip will extend automatically when the ramp cylinder finishes its stroke. The ramp cylinder will retract when the pump stops running. An emergency stop will be realized while the solenoid valve is energized. The lowering speed of both the ramp and the lip is adjusted by the throttle valves in the system.

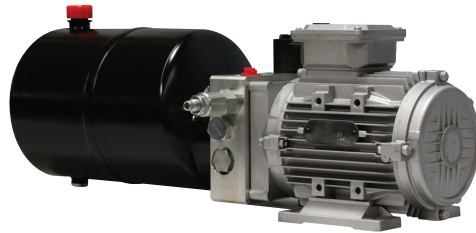

系统工作原理

Hydraulic Circuit Diagram

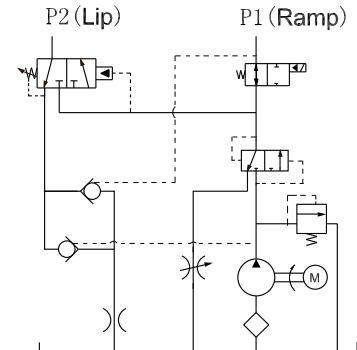

外形尺寸图 Outline Dimension

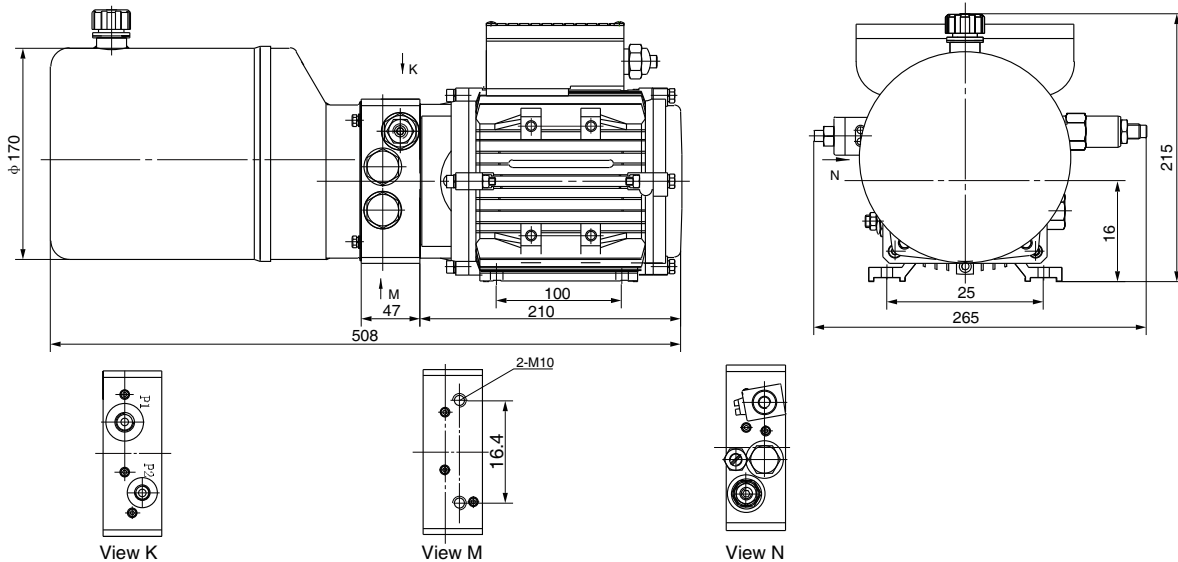

型号规格说明 Model Specifications

Model 型号	Motor Volt 电机电压	Motor power 电机功率	Motor speed 电机转速	Displacement 油泵排量	System pressure 溢流阀压力	Sequence pressure 顺序阀压力	Tank Capacity 油箱容量
YBZ-E2.1B4E84/1	380VAC	0.75KW	1450RPM	2.1mL/r	13MPa	8MPa	6L
YBZ-E2.7B4E84/1				2.7mL/r	10MPa	7.5MPa	

说明: 1.如需不同流量的泵、压力、电机功率等系统参数，请查看液压动力单元型号说明。

2.如需手动应急装置，请在订货时说明。

Remark: 1. Please go to page 38 or consult our sales engineer for the different pump displacement, motor power or tank capacity.

2. The manual override function is available on request.

注意事项 Special Notes

1. 此动力单元不可连续运转（1分钟ON，9分钟OFF），可重复工作。
2. 按装前必须保证油缸、油管、接头等液压元件清洁无任何杂质粘附。
3. 液压油粘度应为15~68CST，应清洁无杂质，推荐使用N46号液压油。
4. 首次启动运行系统后，应立即检查油箱中的油量是否充足。
5. 系统使用第一个100小时后，应更换液压油，以后每3000小时更换一次液压油。

1. This power unit is of S3 duty, i.e., which can only work intermittently and repeatedly, 1 minute on and 9 minutes off.
2. Clean all the hydraulic parts concerned before mounting the power unit.
3. Viscosity of the hydraulic oil should be 15~68 cst, which should also be clean and free of impurities. N46 hydraulic oil is recommended.
4. Check the oil level in the tank after the initial operation of the power unit.
5. Oil changing is required after the initial 100 operation hours, afterwards once every 3000 hours.